

# Vibro-EM.3

## ANTIVIBRATION ELASTIC MOUNTS (TYPE 3)

### APPLICATIONS

The antivibration elastic mount **Vibro EM.3** can be used to absorb vibration in air handling units, air conditioning units, pumps, air compressors, ventilators, transformers, motor generators, cutting machines, printing machines, lifts, etc. especially when machine fastening is necessary.

### DESCRIPTION

**VIBRO-EM.3** is an advanced research result and it is made by an elastomer that includes additional substances that improve its antivibration properties.

All the metal parts are covered by rubber and are protected from Oxidation too.

The top and bottom surface have lined shapes that increase friction and reduce the surface slipping.

The top part **Vibro EM.3** has an M-12 thread and a tightening nut. The bottom base has two 9mm holes. So that the antivibration mount can be fastened to the foundation and also the machine

### SELECTION TABLE

In order to expand the load range of the antivibration mount, **Vibro - EM.3** is made in three rubber hardnesses. Every hardness has a color code and the following characteristics

TYPE	LOAD RANGE (Kp*)
<b>BLUE</b>	100 - 250
<b>WHITE</b>	200 - 400

\*1 (Kp=10N)

### DYNAMIC CHARACTERISTICS

**Deflection (at maximum load) :** 4 mm

**Natural frequency (at maximum load) :** 8 Hz



**Vibro - MS**

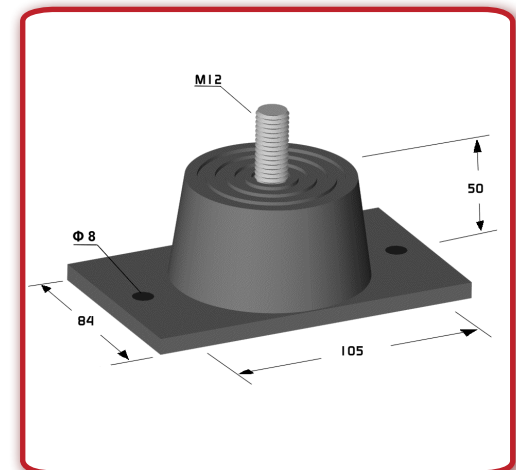

Quality assurance system according to **ISO 9001.2000**.

**ALPHA ACOUSTIKI LTD**

19 Kampouroglou street, 11525 Athens GREECE

T.: +30 210 6779875 - F: +30 210 6779269

[www.vibro.gr](http://www.vibro.gr) - [info@vibro.gr](mailto:info@vibro.gr)