

# A12038-S

120x120x38mm(4.7"x4.7"x1.5") 

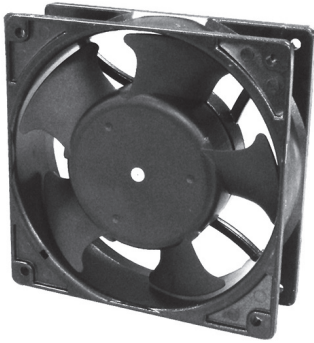

**HOUSING** Aluminum Die Casting, Painted Black  
**IMPELLER** Thermoplastic PBT, UL94V-0  
**BEARING** Ball or Sleeve  
**OPERATING TEMPERATURE** -10°C to +70°C  
**INSULATION** Class A  
**OPERATING VOLTAGE RANGE** 100 VAC to 120 VAC for 115V Type  
 200 VAC to 240 VAC for 230V Type  
**DIELECTRIC STRENGTH** 5mA Max. at 1500 VAC for 1 second  
**INSULATION RESISTANCE** 10M Ω min. @500 VDC  
**MOTOR TYPE** Shaded Pole Motor  
**SAFETY** Impedance Protected  
**TERMINATION** Terminals or Lead Wire  
**WEIGHT** 515 g  
**ROHS COMPLIANCE** Yes  
**IP LEVEL** IP21 (Special IP Rating On Request)

# 120 mm

120 mm

## DIMENSION

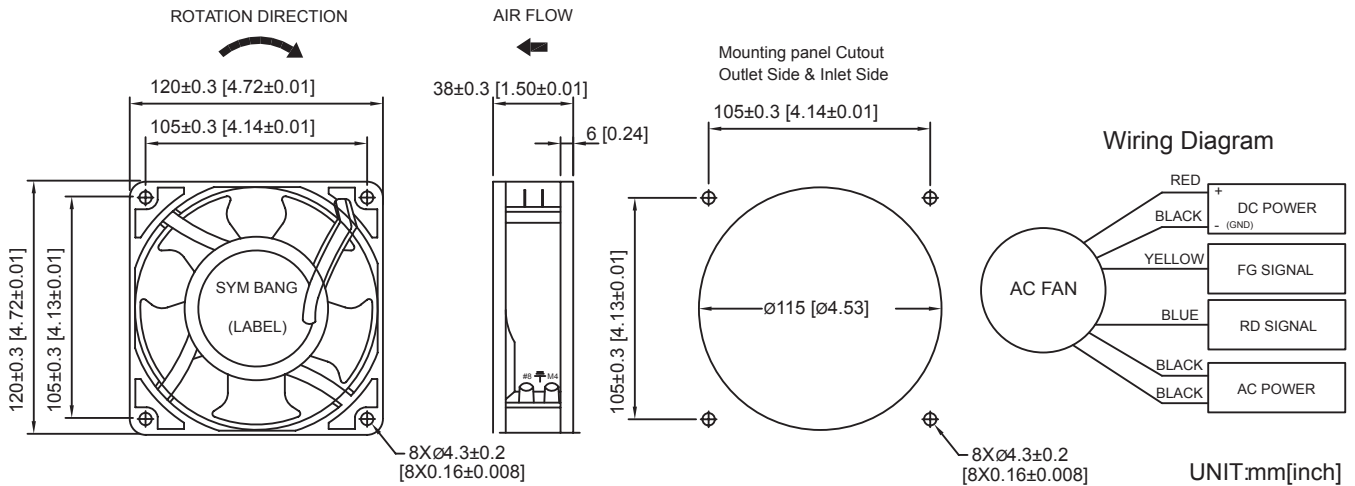

## SPECIFICATION

MODEL NO.	RATED VOLTAGE (V)	FREQUENCY (Hz)	RATED CURRENT (A)	INPUT POWER (W)	SPEED (RPM)	MAX. AIR PRESSURE		MAX. AIR FLOW		NOISE dB(A) @1M
						inchH <sub>2</sub> O	mmH <sub>2</sub> O	CFM	m <sup>3</sup> /min	
A12038V24H-S	24	50/60	0.99/0.86	16.5/14.7	2600/2800	0.11/0.13	2.8/3.5	24/28	0.7/0.8	30
A12038V115H-S	115	50/60	0.27/0.24	21.4/18.7	2650/3000	0.23/0.28	5.8/7.0	88/107	2.5/3.1	42
A12038V115M-S	115	50/60	0.16/0.15	13.0/12.5	2500/2400	0.19/0.21	4.9/5.4	63/71	1.8/2.0	35
A12038V115L-S	115	50/60	0.12/0.11	10.5/10.0	2100/1800	0.11/0.05	2.9/1.5	53/50	1.5/1.4	26
A12038V230H-S	230	50/60	0.13/0.12	21.4/18.7	2650/3000	0.23/0.28	5.8/7.0	88/107	2.5/3.1	42
A12038V230M-S	230	50/60	0.08/0.07	13.0/12.5	2500/2400	0.19/0.21	4.9/5.4	63/71	1.8/2.0	35
A12038V230L-S	230	50/60	0.05/0.04	10.5/10.0	2100/1800	0.11/0.05	2.9/1.5	53/50	1.5/1.4	26

## AIR PERFORMANCE

