



S&P presents a new concept

Demand Controlled Ventilation

Up to 55% savings in energy
consumption

Reduced CO₂ emissions

Improvement of the environment



ENERGY
EFFICIENT



VENTILATION
SYSTEM

Efficient Ventilation Systems



ENERGY EFFICIENT



Energy is scarce and expensive. One of the principal challenges of manufacturers of all sorts of equipment is to produce devices that are much more efficient, reducing consumption without sacrificing performance.

S&P, a world leader in the ventilation market, has anticipated this future by presenting the Energy Efficient Ventilation System (EEVS) concept.



VENTILATION SYSTEM

The **EEVS concept** aims to promote energy savings in ventilation installations. To do this, we propose Demand Controlled Ventilation - DCV, which enables the user to control the performance of their installation, adjusting it to real needs according to use or ambient conditions of the premises to be ventilated. To achieve this, we use low-consumption fans and a wide range of **intelligent elements**:

- Control elements, speed regulators, frequency inverters
- Presence detectors
- CO₂, temperature and humidity sensors
- Pressure sensors
- Motorised shutters
- Twin flow inlets valves



ENERGY SAVINGS, REDUCED EMISSIONS AND IMPROVEMENT OF THE ENVIRONMENT

Everyone's responsibility

Saving energy should be a commitment of society as a whole: Government, companies and private individuals. Beyond the Kyoto Protocol, which indicated that the EU should reduce CO2 emissions by 8%, in Soler & Palau we are working to market efficient ventilation products and systems that not only reduce these emissions, but at the same time offer savings both in energy consumption as well as the cost of recycling products.

Cost savings

The increase of energy costs is unstoppable, affecting both the competitiveness of companies as well as private individuals. Manufacturers must clearly work hard to market ever more efficient products that contribute to reduce this economic impact.

Life-cycle cost

A mechanical product, with an average life span of 10 years, has a total life-cycle cost as indicated below:

- Investment: 10%
- Maintenance: 5%
- Operation cost: 85%

It is clear that any action to improve energy efficiency of the products will automatically mean a considerable saving in life-cycle cost.

Recyclability

Using recyclable materials as well as designing products so that major components can be replaced, avoids having to dump tonnes of waste material. This results in lower product costs, and significantly reduces the cost and energy required to process waste.

Compliance with legislation

The European Energy Performance of Buildings Directive proposes savings of over 20% in energy consumption in buildings by 2010. EU countries have carried out or are in the process of making legislative changes to adapt to these requirements, demanding greater energy efficiency while at the same time providing a cleaner and healthier interior atmosphere.

Health and Productivity

It is clear that with this approach, the European Directive, in addition to saving energy, intends to protect people's health. A healthy work environment also helps to reduce fatigue and sickness in workers, resulting in greater productivity and reduced absenteeism due to illness.



DCV

Demand controlled ventilation



**ENERGY
EFFICIENT**



**VENTILATION
SYSTEM**



Respect for the environment, a historical responsibility for S&P

Any policy that was not respectful of the environment, would be incompatible with S&P's philosophy.

Our ongoing concern for the environment makes us conscious of the legacy we are leaving for future generations.

Several years ago, S&P achieved ISO-14001 certification for Environmental Management. This reinforces our commitment to caring for the environment by filtering gases emitted, and recycling all liquid and solid waste generated in our production processes.

Today, we are still the only company in this sector holding this certification.



Intelligent Ventilation Systems Rational use of energy

Field experience has shown us that most premises (offices, shops, restaurants, meeting rooms, gyms, etc.), average daily occupancy does not exceed 60%.

S&P have developed a series of solutions under a concept called Demand Controlled Ventilation (DCV), which proposes ventilation systems comprising of fans with electronic and mechanical elements.

Our DCV solutions guarantee that the system uses only the energy required to provide ventilation based on occupancy.

This means a huge saving of energy during the lifetime of the installation.



DCV

Demand controlled ventilation





*e*fficiency

*e*conomy

*e*cology

DCV

Demand controlled ventilation



efficiency

Percentage of occupation %

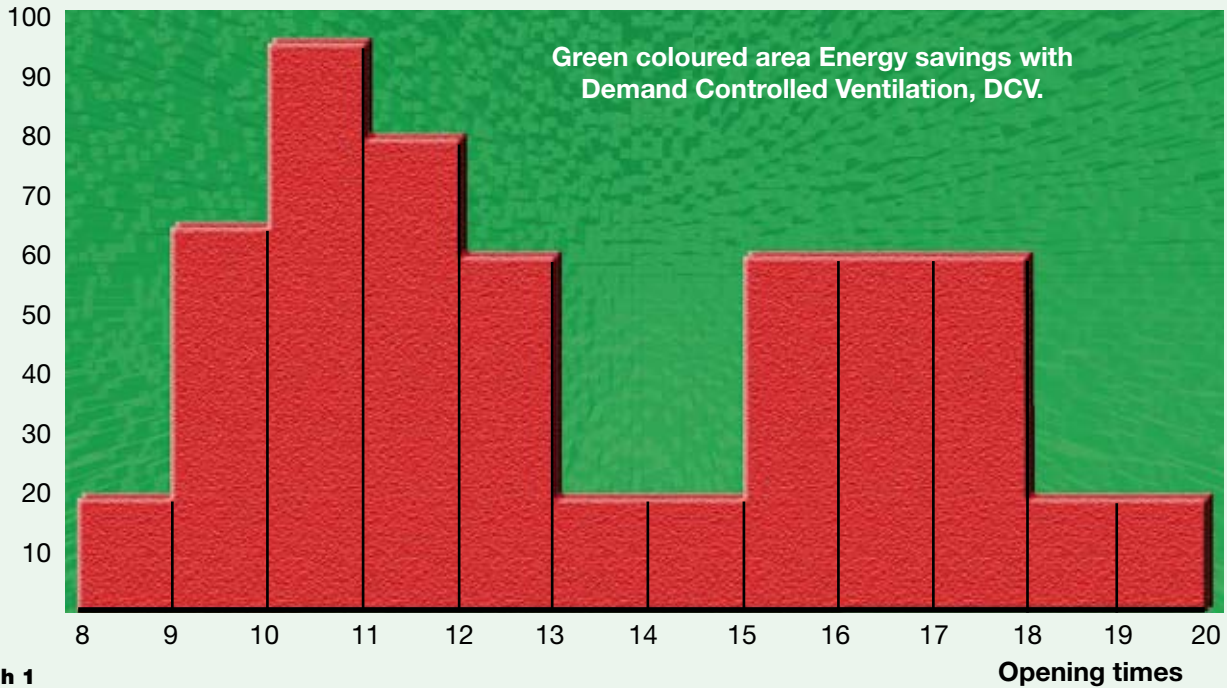

Graph 1

It has been seen that in commercial offices, average occupancy does not exceed 60%. A traditional ventilation system based on maximum power uses energy unnecessarily. By using an intelligent system of Demand Controlled Ventilation, we can achieve significant savings of energy and money.

A commonly accepted ventilation rate should be at least 12.5 l/s per person, equivalent to 45 m³/h.

If we consider the case of an office (Graph 1) with a maximum capacity of 80 people, occupancy during working hours expressed as a percentage on the vertical axis.

ENERGY SAVINGS WITH DCV VENTILATION

	Opening times	Office occupation %	Office occupation (absolute numbers)	Three Phase Fan			
				Airflow extracted without DCV (m ³ /h)	Power consumption without DCV (W/h)	Airflow necessary with DCV (m ³ /h)	Power consumption with DCV (W/h)
	8-9	20	16	3.600	1.100	720	220
	9-10	65	52	3.600	1.100	2.340	715
	10-11	95	76	3.600	1.100	3.420	1.045
	11-12	80	64	3.600	1.100	2.880	880
	12-13	60	48	3.600	1.100	2.160	660
	13-14	20	16	3.600	1.100	720	220
	14-15	20	16	3.600	1.100	720	220
	15-16	60	48	3.600	1.100	2.160	660
	16-17	60	48	3.600	1.100	2.160	660
	17-18	60	48	3.600	1.100	2.160	660
	18-19	20	16	3.600	1.100	720	220
	19-20	20	16	3.600	1.100	720	220
Consumption kW/h DAY					13,2		6,38
Consumption kW/h YEAR	50 weeks / year				3.300		1.595
Reduction of consumption kW/h YEAR by using DCV							1.705
SAVINGS (€/year)				at a Price of kW/h = 0.093			158
CO₂ REDUCTION (Kg/year)				1 kW/h = 0,5 Kg of CO₂			853
SAVINGS (€) Life cycle (10 years)							1.580
CO₂ REDUCTION (Kg) Life cycle (10 years)							8.530

economy

In the case of a small office such as the example below, a DCV system could save up to **17.500** € in 10 years.



ENERGY SAVING WITH DCV VENTILATION

	Days	ΔT	Ventilation consumption without DCV (kW/h)	Ventilation consumption with DCV (kW/h)
JANUARY	22	20	6.336	3.062
FEBRUARY	20	20	5.760	2.784
MARCH	22	0	0	0
APRIL	17	0	0	0
MAY	22	-10	3.168	1.531
JUNE	21	-10	3.024	1.461
JULY	22	-10	3.168	1.531
AUGUST	8	-10	1.152	556
SEPTEMBER	19	0	0	0
OCTOBER	22	0	0	0
NOVEMBER	21	20	6.048	2.923
DECEMBER	16	20	4.608	2.227
YEARLY TOTAL			33.264	16.075
Reduction of consumption kW/h YEAR by using DCV				17.189
SAVINGS (€/year)		at a price of kW/h = 0.093		1.598
CO₂ REDUCTION (Kg/year)		1 kW/h = 0,5 Kg of CO₂		8.595
SAVINGS (€) Life cycle (10 years)				15.980
CO₂ REDUCTION (Kg) Life cycle (10 years)				85.950

ecology

In the case of a small office such as the one in the example, a DCV system could save emissions of up to

95 Tonnes of CO₂ in a 10-year period.



DEMAND CONTROLLED VENTILATION SYSTEMS

DCV

Below is a graphic representation of some of the many possibilities of Demand Controlled Ventilation and how the different elements are combined to provide optimum, energy efficient ventilation.

Any of the solutions presented can be implemented with Simple Extract only, Balanced supply and extract, or Heat Recovery systems.

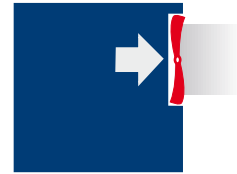

EXTRACT

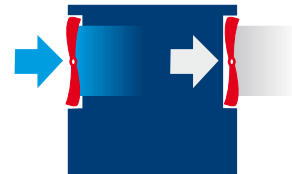

SUPPLY &
EXTRACT



HEAT
RECOVERY



SINGLE-ZONE SYSTEMS

DEMAND CONTROLLED VENTILATION SYSTEMS WITH PRESENCE DETECTION P.I.R.

For use when the presence of people should activate or increase the ventilation system demands.

ON / OFF type

Example: offices or rooms used occasionally.

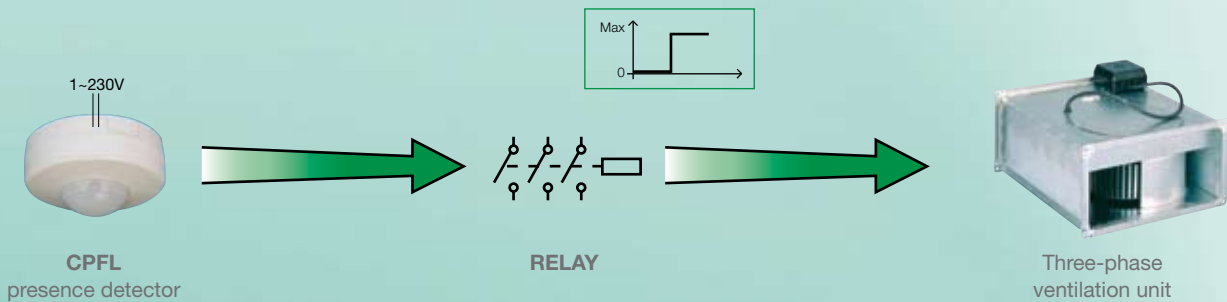

INSTALLATION WITH THREE-PHASE FANS

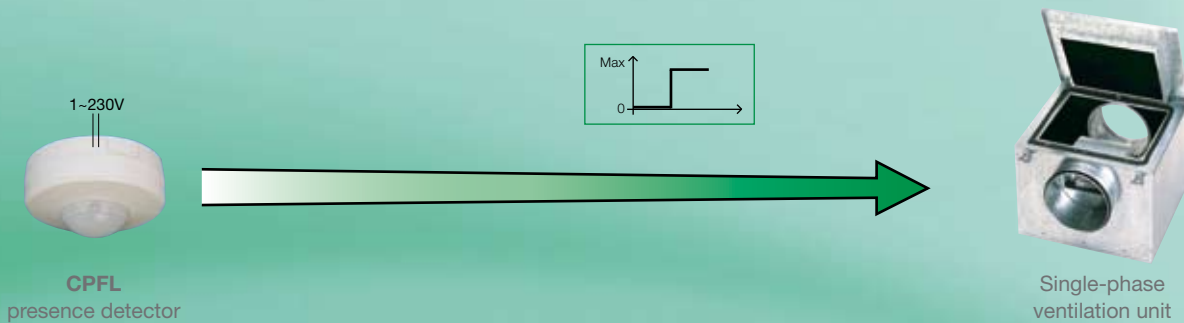

INSTALLATION WITH SINGLE-PHASE FANS

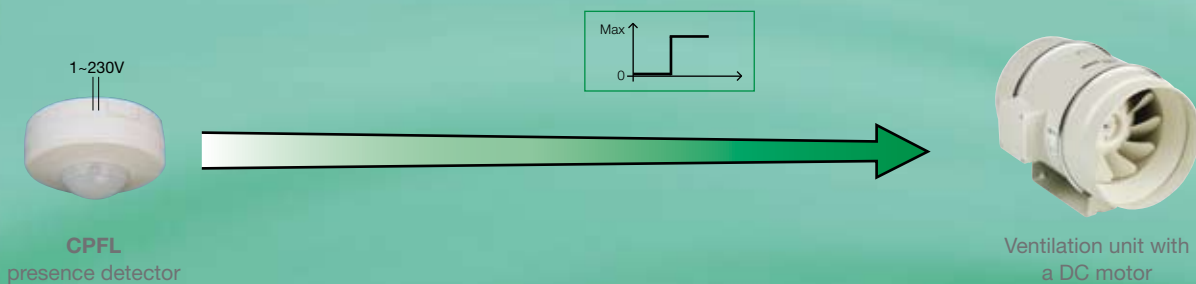

INSTALLATION WITH SINGLE-PHASE FANS WITH A DC MOTOR

HOW THE SYSTEM WORKS

The presence of one or more people in the room activates the ventilation system.

When the room is empty the system will return to the previous status.

ADVANTAGES OF THE SYSTEM

The room is only ventilated when occupied.

SINGLE-ZONE SYSTEMS

Minimum / Maximum type

Example: Offices or rooms used occasionally requiring minimum maintenance ventilation.

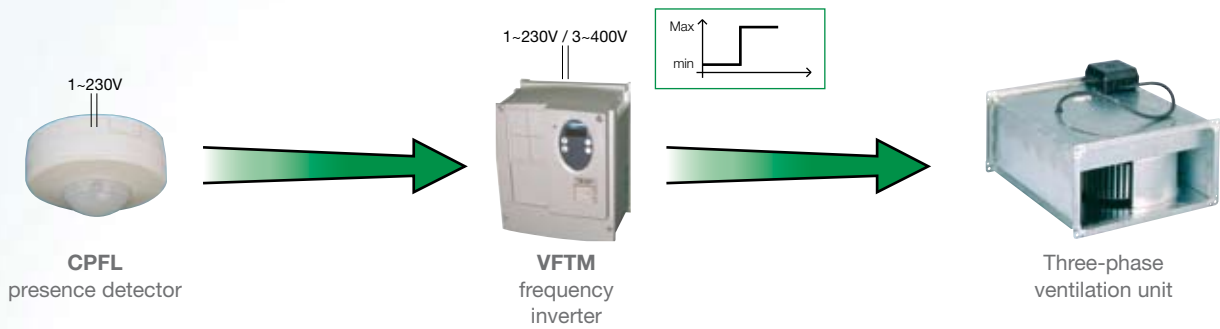

INSTALLATION WITH THREE-PHASE FANS

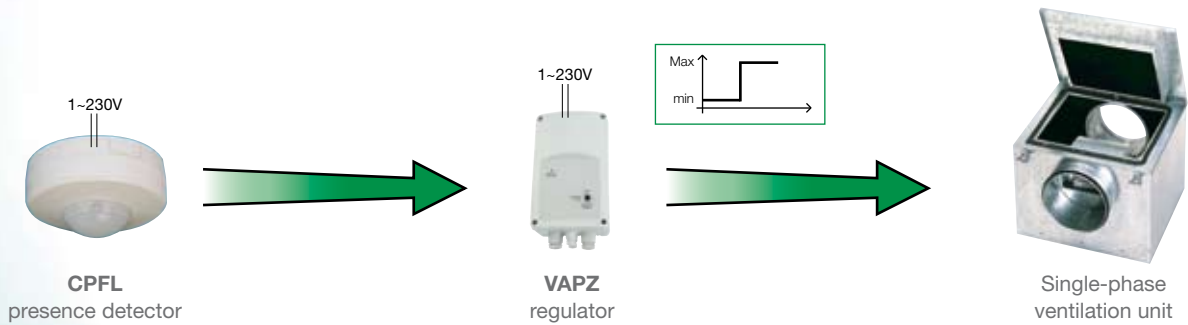

INSTALLATION WITH SINGLE-PHASE FANS

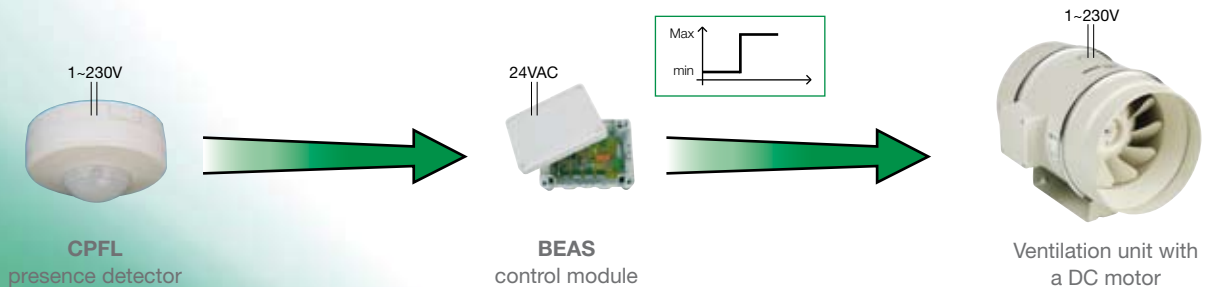

INSTALLATION WITH SINGLE-PHASE FANS WITH A DC MOTOR

HOW THE SYSTEM WORKS

The installation will be switched on at minimum power either by a Timer or manually, to provide maintenance ventilation. The presence of one or more people in the room will be identified by the presence Detector, which through a speed control regulator, will increase the fan to maximum speed. When the room is empty the system will return to maintenance status.

ADVANTAGES OF THE SYSTEM

Maximum power will only be used when there are people in the room.

SINGLE-ZONE SYSTEMS

DEMAND VENTILATION CONTROL SYSTEMS BY CO₂

Proportional type

For use when the occupation of the premises is variable and the ventilation flow must be regulated according to the occupancy levels. Example: Open plan offices, Meeting rooms, Commercial premises, Cinemas, Restaurants, Public premises.

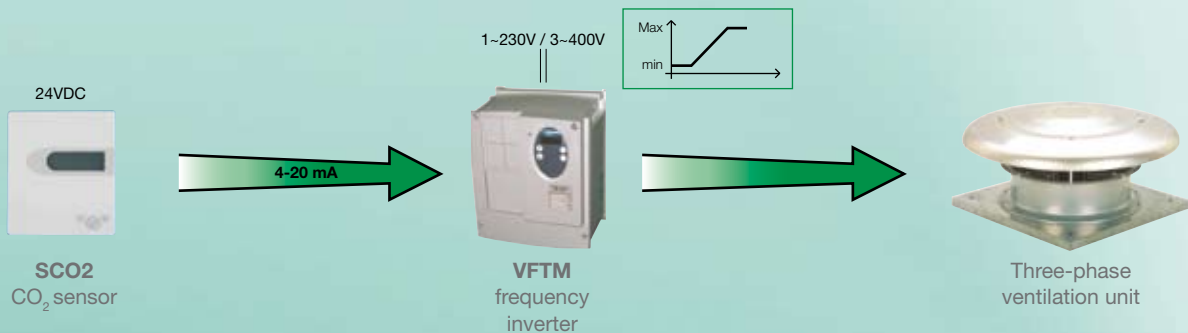

INSTALLATION WITH THREE-PHASE FANS

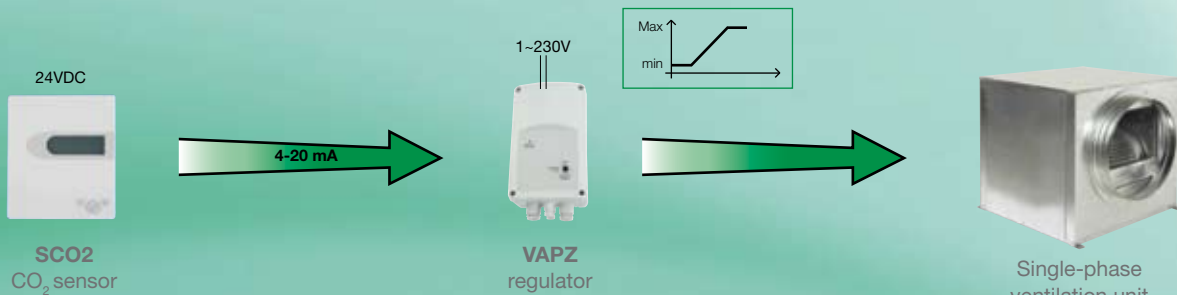

INSTALLATION WITH SINGLE-PHASE FANS

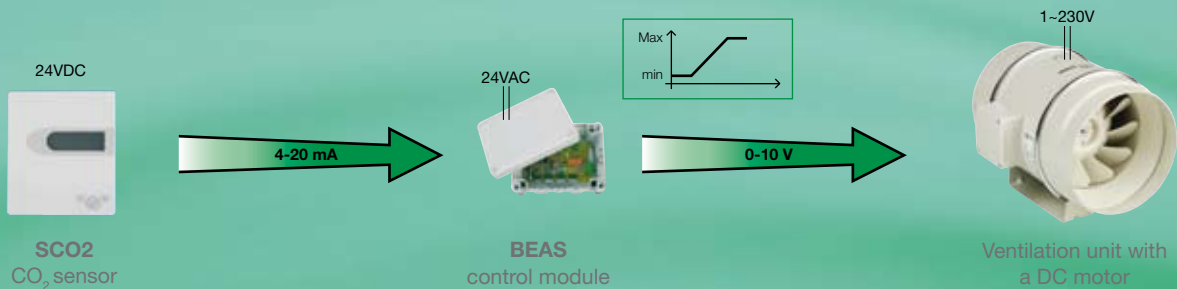

INSTALLATION WITH SINGLE-PHASE FANS WITH A DC MOTOR

HOW THE SYSTEM WORKS

The system will be switched on either by a Timer or manually and will ventilate the room at a low occupancy ventilation rate at reduced power.

The CO₂ Sensor detects an increase in carbon dioxide levels in the room, the fan speed will be increased as required through an automatic speed controller. Where carbon dioxide levels fall, again the speed controller will adjust the ventilation rate by reducing the fan speed.

ADVANTAGES OF THE SYSTEM

Ventilation will be varied to suit the room occupancy condition thereby providing considerable energy savings over a standard total ventilation.

SINGLE-ZONE SYSTEMS

DEMAND VENTILATION CONTROL SYSTEMS BY RELATIVE HUMIDITY

Proportional type

For use when ventilation needs are conditioned by a variation in relative humidity.
Example: Public baths, gyms, sports centres, etc.

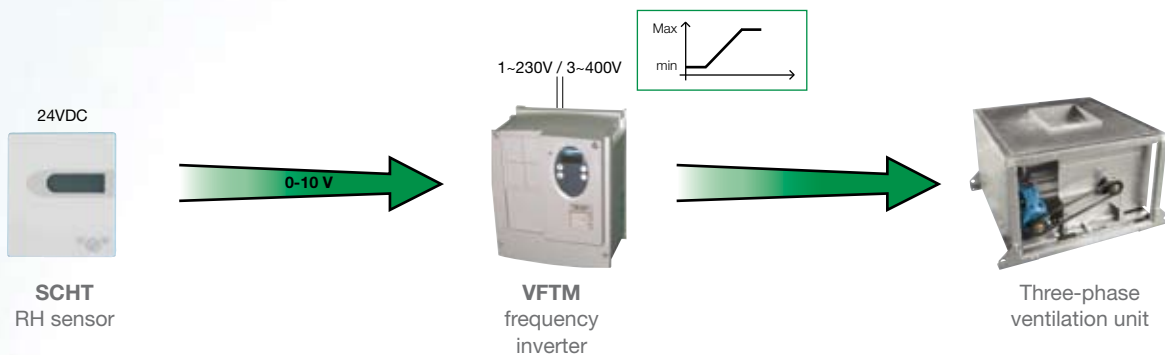

INSTALLATION WITH THREE-PHASE FANS

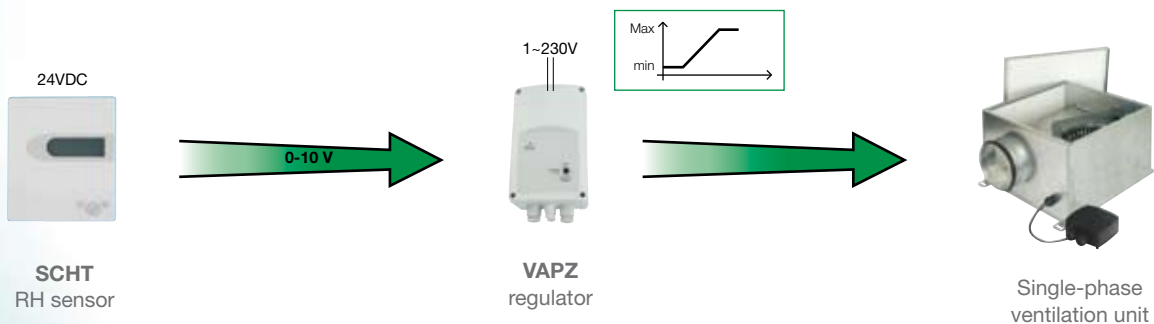

INSTALLATION WITH SINGLE-PHASE FANS

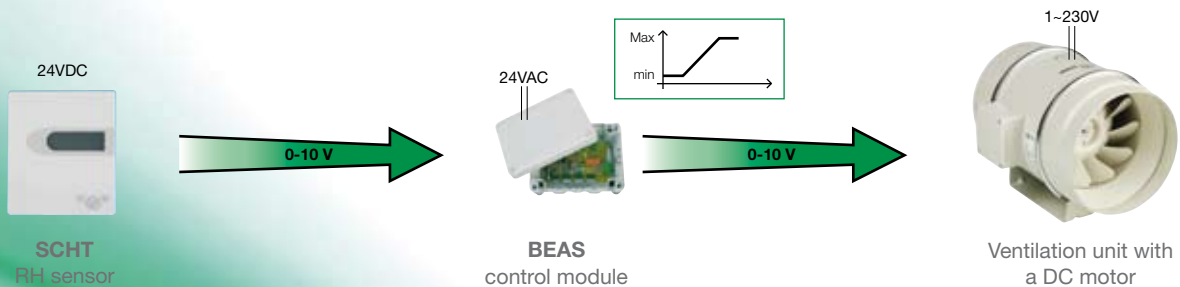

INSTALLATION WITH SINGLE-PHASE FANS WITH A DC MOTOR

HOW THE SYSTEM WORKS

The ventilation will be activated either by a timer, or manually, and will ventilate the room at minimum power.

When the R.H. Sensor detects increased humidity a signal is sent to speed controller to increase the fan speed. As humidity falls, the fan speed will be reduced by the sensor signaling the speed controller.

ADVANTAGES OF THE SYSTEM

Ventilation, above the minimum maintenance level, will only be activated when the relative humidity in a room exceeds a pre-set level. This provides significant energy savings in comparison to total ventilation systems.

MULTI ZONE SYSTEMS

CONTROLLED VENTILATION SYSTEMS BY PRESENCE DETECTION

Minimum / Maximum type

The idea is to maintain a ducted ventilation system at a fixed pressure, regardless of the airflow moved.

A typical application is an installation with a fan connected to a system of multiple intakes each of which can be open or closed.

Example: Office premises with private closed offices, independent washrooms, etc.

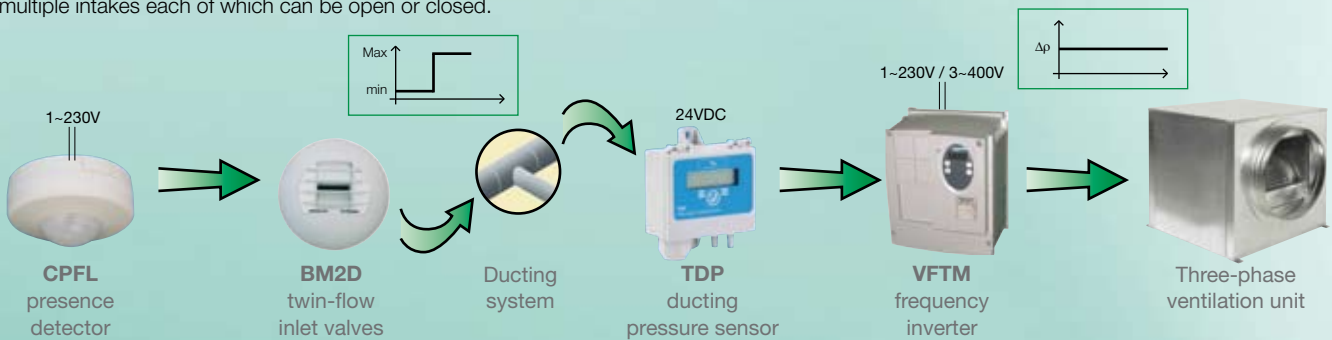

INSTALLATION WITH THREE-PHASE FANS

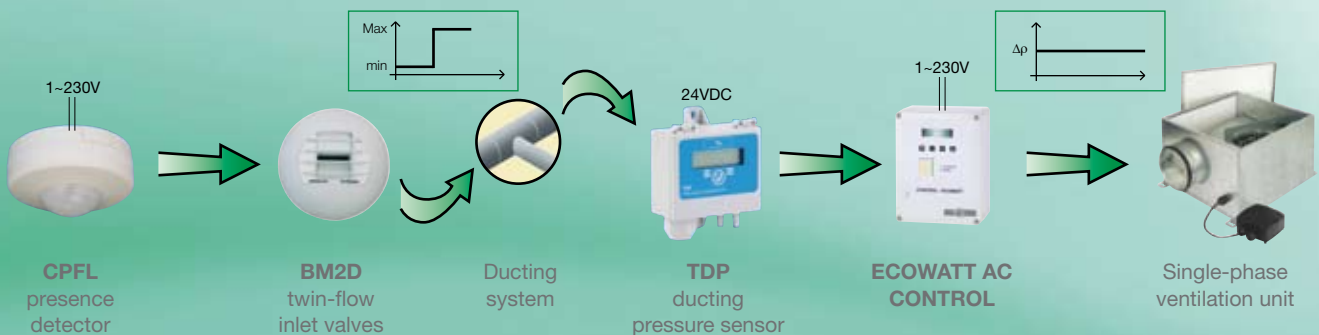

INSTALLATION WITH SINGLE-PHASE FANS

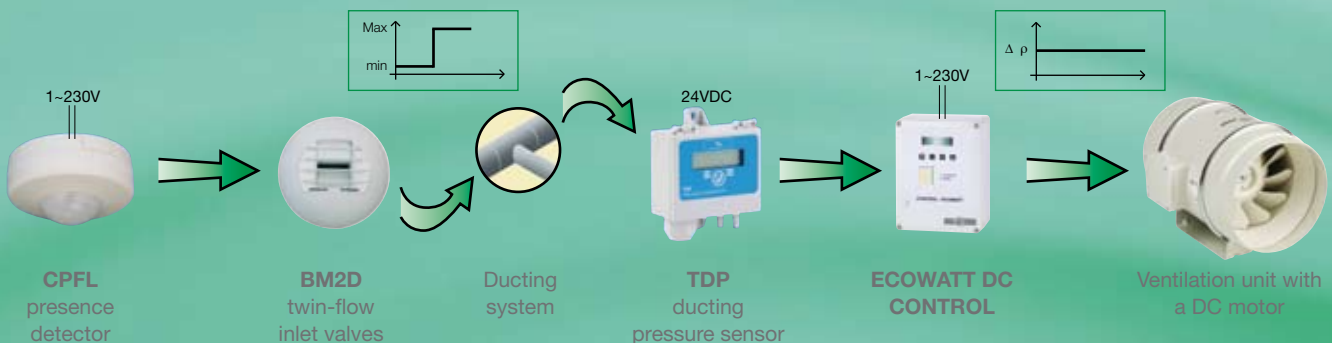

INSTALLATION WITH SINGLE-PHASE FANS WITH A DC MOTOR

HOW THE SYSTEM WORKS

The system is sized to cater for the maximum airflow, if all offices are occupied. The pressure generated in the system, at the maximum ventilation demand is determined. Each occupied area will be maintained at a minimum ventilation level, determined by ambient conditions. The system will be switched manually, or by a timer.

When the PIR detects the presence of a person in the room, it will signal the twin flow suction inlet, which will fully open. This will create a pressure imbalance in the system, which will be immediately detected by the pressure sensor. This sensor will in turn signal the speed controller to adjust the fan speed to meet the new condition. This procedure will be repeated each time the PIR detects a presence.

ADVANTAGES OF THE SYSTEM

Specific ventilation for each room served by the system using maximum power only when fully occupied.

This results in considerable energy saving in comparison to a ventilation system without demand control.

MULTI ZONE SYSTEMS

DEMAND CONTROL VENTILATION SYSTEMS BY CO₂

DCV

Proportional type

For use in rooms with variable occupancy.

Example: Offices with multiple meeting rooms, hotels with various function rooms, restaurants with several dining rooms, etc.

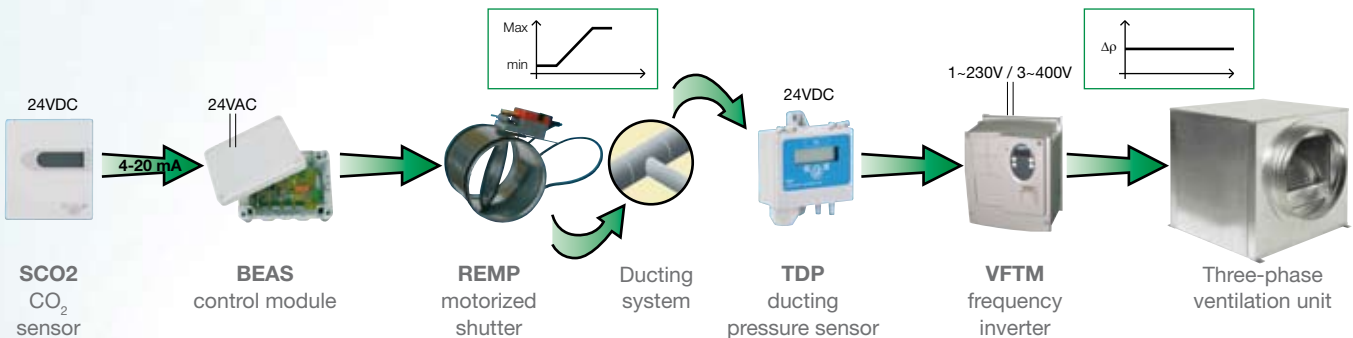

INSTALLATION WITH THREE-PHASE FANS

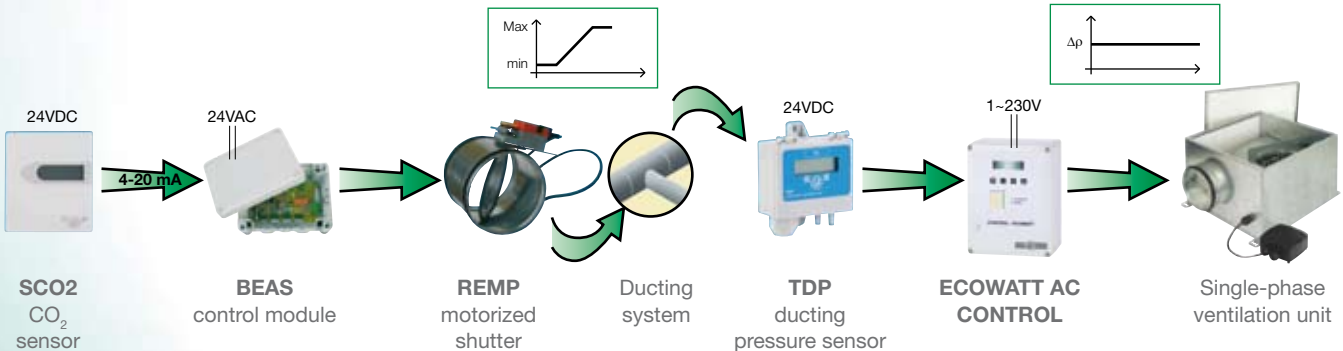

INSTALLATION WITH SINGLE-PHASE FANS

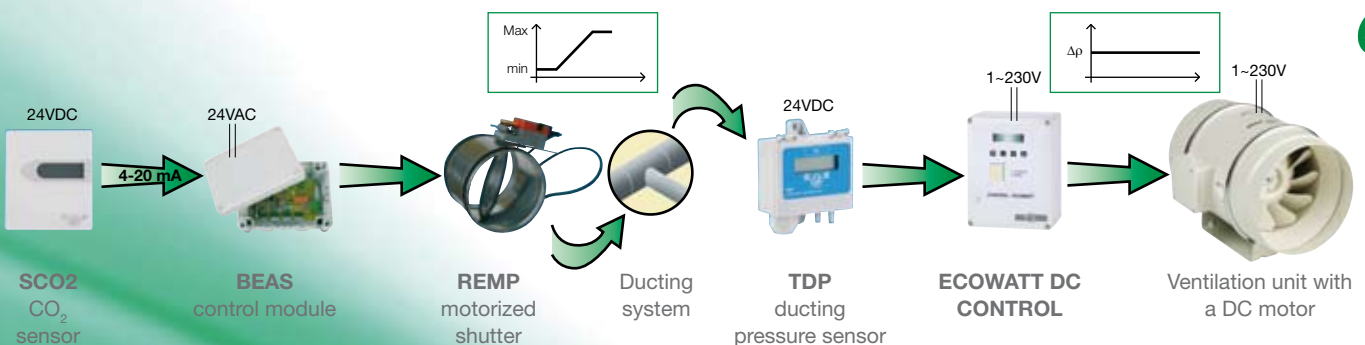

INSTALLATION WITH SINGLE-PHASE FANS WITH A DC MOTOR

Air Control
Pressure/CO₂

Air Control
Pressure/CO₂

Demand controlled ventilation

HOW THE SYSTEM WORKS

The ventilation will be activated either by a timer, or manually, and will ventilate the room at minimum power.

As these are rooms which typically have variable occupancy levels, the sensor will detect the CO₂ level created by the number of people present and will send the reading as a digital signal to the Motorized shutter that will open (or close) in proportion to the air volume required. This variation in airflow will cause pressure differences in the system, which in turn will be detected by the pressure sensor. This sensor will in turn signal the speed controller to adjust the fan speed to meet the new condition. This system can also be combined with a minimum ventilation level, independent of room occupancy.

ADVANTAGES OF THE SYSTEM

Ventilation is determined by occupancy levels resulting in significant energy savings in comparison to a total ventilation system.



Summary of Demand Controlled Ventilation (DCV) systems. List of S&P products to provide Intelligent DCV

SINGLE ZONE

OFF - ON		MIN - MAX		PROPORTIONAL			
Products	Ref. S&P	Products	Ref. S&P	Products (CO ₂)	Ref. S&P	Products (R.H. or Temp.)	Ref. S&P
SINGLE PHASE FAN		SINGLE PHASE FAN		SINGLE PHASE FAN		SINGLE PHASE FAN	
PRESENCE DETECTOR	CPFL	START (TIMER, MANUAL)	NOT SUPP.	START (TIMER, MANUAL)	NOT SUPP.	START (TIMER, MANUAL)	NOT SUPP.
		PRESENCE DETECTOR	CPFL	CO ₂ (4-20mA) SENSOR	SCO2	RH/T SENSOR (0-10V)	SCHT
		SINGLE PHASE REGULATOR	VAPZ	SINGLE PHASE REGULATOR	VAPZ	SINGLE PHASE REGULATOR	VAPZ
THREE PHASE FAN		THREE PHASE FAN		THREE PHASE FAN		THREE PHASE FAN	
PRESENCE DETECTOR	CPFL	START (TIMER, MANUAL)	NOT SUPP.	START (TIMER, MANUAL)	NOT SUPP.	START (TIMER, MANUAL)	NOT SUPP.
RELAY	NOT SUPP.	PRESENCE DETECTOR	CPFL	CO ₂ (4-20mA) SENSOR	SCO2	RH/T SENSOR (0-10V)	SCHT
		FREQUENCY INVERTER	VFTM	FREQUENCY INVERTER	VFTM	FREQUENCY INVERTER	VFTM
ECOWATT FAN		ECOWATT FAN		ECOWATT FAN		ECOWATT FAN	
PRESENCE DETECTOR	CPFL	START (TIMER, MANUAL)	NOT SUPP.	START (TIMER, MANUAL)	NOT SUPP.	START (TIMER, MANUAL)	NOT SUPP.
		PRESENCE DETECTOR	CPFL	CO ₂ (4-20mA) SENSOR	SCO2	RH/T SENSOR (0-10V)	SCHT
		CONTROL MODULE	BEAS	CONTROL MODULE	BEAS	CONTROL MODULE	BEAS
APPLICATIONS		APPLICATIONS		APPLICATIONS		APPLICATIONS	
For applications where the presence of people is occasional and a minimum ventilation is not required when the premises is empty.		For installations where the presence of people is occasional and a minimum ventilation is required when the premises is empty and the fan will work full speed when someone enters.		For installations where from a minimum ventilation, a proportional increase of airflow is required according to the CO ₂ concentration.		For installations where from a minimum ventilation, a proportional increase of airflow is required according to the degree of ambient R.H. or Temperature.	

MULTI ZONE

MIN / MAX		PROPORTIONAL CO ₂	
Products	Ref. S&P	Products (CO ₂)	Ref. S&P
SINGLE PHASE FAN		SINGLE PHASE FAN	
START (TIMER, MANUAL)	NOT SUPPLIED	START (TIMER, MANUAL)	NOT SUPPLIED
PRESENCE DETECTOR	CPFL	CO ₂ SENSOR (4-20mA)	SCO2
SHUTTER or TWIN-FLOW INLET	RMVT or BM2D	CONTROL MODULE	BEAS
PRESSURE SENSOR	TDP	PROPORTIONAL SHUTTER	REMP
CONTROL FOR DEMAND CONTROLLED VENTILATION	ECOWATT AC CONTROL	PRESSURE SENSOR	TDP
		CONTROL FOR DEMAND CONTROLLED VENTILATION	ECOWATT AC CONTROL
THREE PHASE FAN		THREE PHASE FAN	
START (TIMER, MANUAL)	NOT SUPPLIED	START (TIMER, MANUAL)	NOT SUPPLIED
PRESENCE DETECTOR	CPFL	CO ₂ SENSOR (4-20mA)	SCO2
SHUTTER or TWIN-FLOW INLET	RMVT or BM2D	CONTROL MODULE	BEAS
PRESSURE SENSOR	TDP	PROPORTIONAL SHUTTER	REMP
FREQUENCY INVERTER	VFTM	PRESSURE SENSOR	TDP
		FREQUENCY INVERTER	VFTM
ECOWATT FAN		ECOWATT FAN	
START (TIMER, MANUAL)	NOT SUPPLIED	START (TIMER, MANUAL)	NOT SUPPLIED
PRESENCE DETECTOR	CPFL	CO ₂ SENSOR (4-20mA)	SCO2
SHUTTER or TWIN-FLOW INLET	RMVT or BM2D	CONTROL MODULE	BEAS
PRESSURE SENSOR	TDP	PROPORTIONAL SHUTTER	REMP
CONTROL FOR DEMAND CONTROLLED VENTILATION	ECOWATT DC CONTROL	PRESSURE SENSOR	TDP
		CONTROL FOR DEMAND CONTROLLED VENTILATION	ECOWATT DC CONTROL
APPLICATIONS		APPLICATIONS	
For installations with separate offices, and occasional presence of people, requiring a minimum level of ventilation when unoccupied, and full power when occupied. In such a multi zone system, it is necessary to maintain a constant pressure in the system.		For installations with separate offices, and occasional presence of people, requiring a minimum level of ventilation when unoccupied, and full an increase in ventilation proportional to the level of CO ₂ . In such a multi zone system, it is necessary to maintain a constant pressure in the system.	

There may be situations where both applications are required, such as an office building with independent offices and meeting rooms.

DCV

Demand controlled ventilation

Ranges of Ventilation Units for use in Intelligent Demand Controlled Ventilation Systems



CAB*

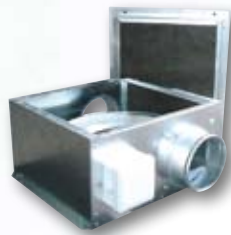

CAB-PLUS



SLIMBOX



CENTRIBOX
CVB-CVT



CVAB-CVAT*



CHVB-CHVT

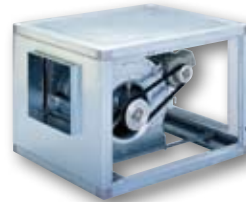

CVTT



CVHT



CVST



TD-MIXVENT



TD-ECOWATT



DIRECT-AIR*
ILB / ILT



IRAB / IRAT



TH-MIXVENT



MAX-TEMP*
CTHB/T-CTVB/T



HCTB-HCTT*



CRHB-CRHT
CRVB-CRVT



HXBR / HXTR



COMPACT*
HCFB/T-HCBB/T
TCFB/T-TCBB/T



Heat Recovery
CADB-S
CADB-D-DI-DC

DCV

Demand controlled ventilation

*For the series marked with an asterisk, it is necessary to order a specific version of motor E-22.